



SPK-3000

Integrated In-motion Weigh/Dimension System

For Total Cost Saving and Accurate Data Collection in Logistics Applications



SPK-4000(Wide conveyor type)

Searching for
a New Balance

International Standard in Logistics Application !!

Designed to measure the weight and dimensions of non-cuboid items as well, suitable for distribution center, courier companies, warehouse and other freight industry.

Large Color Touch Panel for smooth and efficient operation

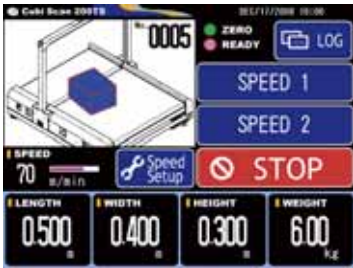

High Speed and Accurate Weighing and Dimensioning

Max Conveyor Speed : 70m/min.
Capacity of Measurement : Max 3,500 objects/hour (if the item length is 50cm)

Large Color Touch Panel

8.4" Color TFT Display guides the operator to perform simple, smooth and efficient operation. Self-diagnostic function is supported through this touch panel display.

Angle Correction Function

Even items slantingly fed onto the conveyor, the dimensions of each item is measured accurately with "Auto Angle Correction Logic" newly developed by DIGI.

Specifications (SPK-3000)

Measuring	Length	15 - 153cm	6 - 60inches
	Width	10 - 90cm	4 - 35.4 inches
	Height	6 - 92cm	2.4 - 36inches
	Increment	0.5cm	0.2inches
	Measuring Device	Photo Sensor	
	Weighing	Capacity	5/50kg
Increment		0.05/0.1kg	0.1/0.2lb
Weighing Device		Load cell	
Belt Speed		30-70m/min (variable)	100-230ft/min (variable)
Required Package Interval		70cm	28inches
Operating Temperature		0 - 40°C	32 - 104°F
Interface	RS-232C/RS-422		
Net Weight	Approx.360kg		
Operating Voltage	AC200-220V(3 φ)		
Power Consumption	300VA		

Dimensions (SPK-3000)

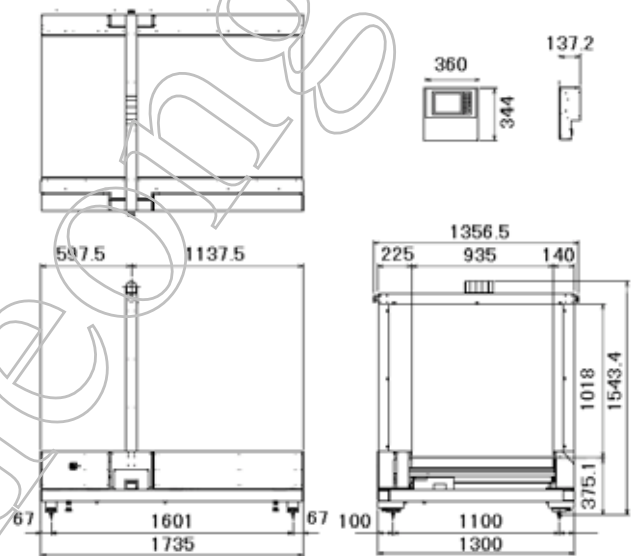

Specifications (SPK-4000)

Measuring	Length	15 - 153cm	6 - 60inches
	Width	10 - 122cm	4 - 48 inches
	Height	6 - 92cm	2.4 - 36inches
	Increment	0.5cm	0.2inches
	Measuring Device	Photo Sensor	
	Weighing	Capacity	5/50kg
Increment		0.05/0.1kg	0.1/0.2lb
Weighing Device		Load cell	
Belt Speed		30-70m/min (variable)	100-230ft/min (variable)
Required Package Interval		70cm	28inches
Operating Temperature		0 - 40°C	32 - 104°F
Interface	RS-232C/RS-422		
Net Weight	Approx.400kg		
Operating Voltage	AC 200-220V(3 φ)		
Power Consumption	300VA		

Dimensions (SPK-4000)

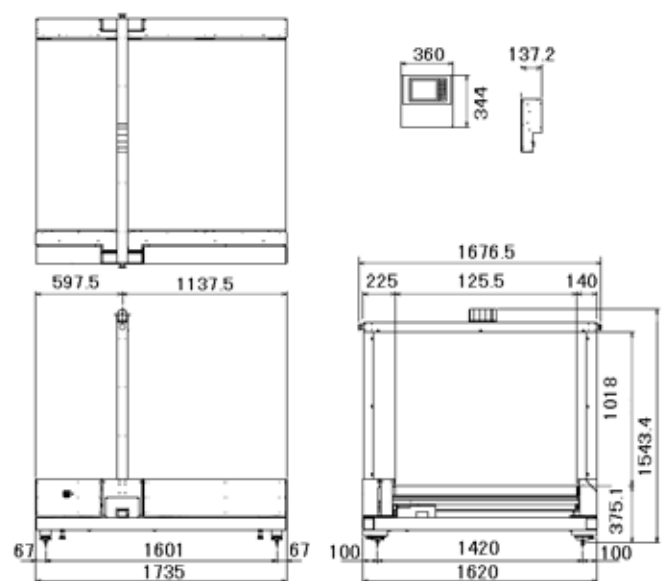

Teraoka Seiko Co., Ltd.

13-12 Kugahara 5-chome, Ohta-ku, Tokyo 146-8580 Japan
TEL : +81-3-3752-2131 FAX : +81-3-3752-2801
http : //teraoka.digi.co.jp/index.nsf e-mail : info@hq.digi.co.jp

* Specifications are subject to change without notice.