



# SM-5500 $\alpha$

## PC Based System Scale Printer

Breaking New Grounds With Salient Features



SM-5500EV $\alpha$

*Searching for  
a New Balance*

## External Dimensions (mm)

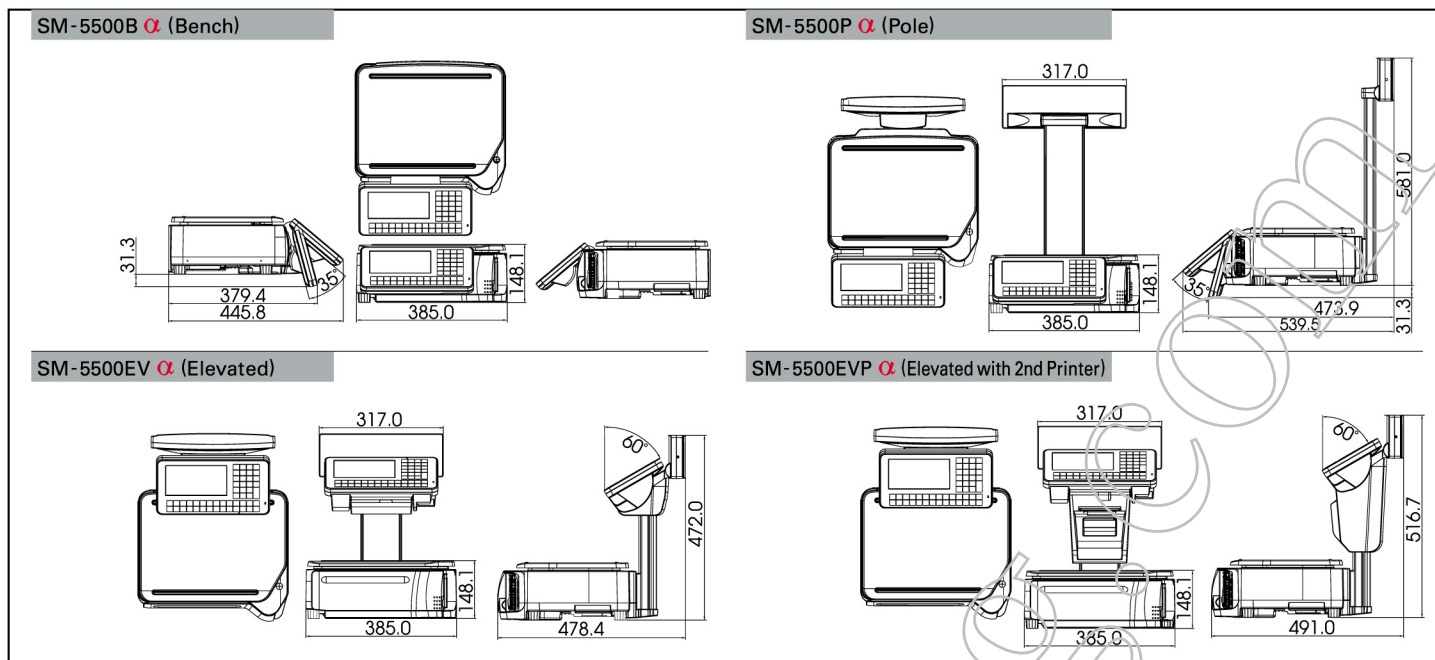

## Specifications

Capacity	Max 6kg	Max 15kg / 30lb	Max 30kg
Single Interval	e = 2g	e = 5g / 0.01lb	e = 10g
Multi Interval	e = 1g	e = 2g	e = 5g
Capacity	Max 3 / 6kg	Max 6 / 15kg	Max 15 / 30kg
Multi Interval	e = 1 / 2g	e = 2 / 5g	e = 5 / 10g

Model	SM-5500B $\alpha$ (Bench)	SM-5500P $\alpha$ (Pole)	SM-5500EV $\alpha$ (Elevated)	SM-5500EVP $\alpha$ (Elevated with 2nd Printer)
Dimension / WxDxH (mm)	385.0 x 445.8 (Max) x 148.1	385.0 x 539.5 (Max) x 581.0	385.0 x 478.4 x 472.0	385.0 x 491.0 x 516.7
Operator Display	7" WVGA with Touch (800 x 480)	○	○	○
Customer Display	7" WVGA (800 x 480)	○	○	○
Display Resolution	1 / 3,000, 1 / 6,000 & 1 / 7,500			
CPU	Dual Core 1.2GHz			
Memory	SD Card 4GB & Above			
Label Size / W x H (mm)	80mm x 240mm (Max)			
Label / Receipt Roll Diameter	125mm (Max)			
Label / Receipt / 2nd Receipt	80mm			
Paper Width / Printing Speed	Up to 150mm / Second*			
Power Source	AC 100 / 110 or 220 / 230 / 240 Volts (50 / 60 Hz) Factory Default			
Operating Temperature	-10°C to +40°C			
Humidity	15% to 85% RH			
Standard Interface	RS232C, Ethernet 10 / 100 Base T, USB 2.0 Host			
Net Weight	12.00kg	14.30kg	15.35kg	16.85kg

Options	Wireless LAN (IEEE 802.11b / g), Scanner (In Built), Card Reader, 2nd Receipt Printer, Linerless Receipt Printer
---------	--

\*To achieve maximum print speed, high sensitivity thermal paper is necessary. Contact DIGI for details.

7" Customer Display



More sales through product marketing, cross merchandising and product information



• ISO 9001



• Specifications are subject to change without prior notice  
• Meet or exceed OIML Class III requirements

### TERAOKA WEIGH-SYSTEM PTE LTD.

4 Leng Kee Road #05-02/03/04/05/11  
SIS Building SINGAPORE 159088  
TEL : +65 6472 2996  
SALES: +65 6378 5387  
FAX : +65 6863 4614  
URL : www.teraoka.com.sg  
E-MAIL : bdd@teraoka.com.sg

### TERAOKA SEIKO CO., LTD.

13-12 Kugahara 5-chome, Ohta-ku,  
Tokyo 146-8580, JAPAN  
TEL : +81-3-3752-2131  
FAX : +81-3-3752-2801  
URL : www.digisystem.com  
E-MAIL : info@hq.digi.co.jp